

Point-to-Point WiFi Bridge Kit Connection Diagram

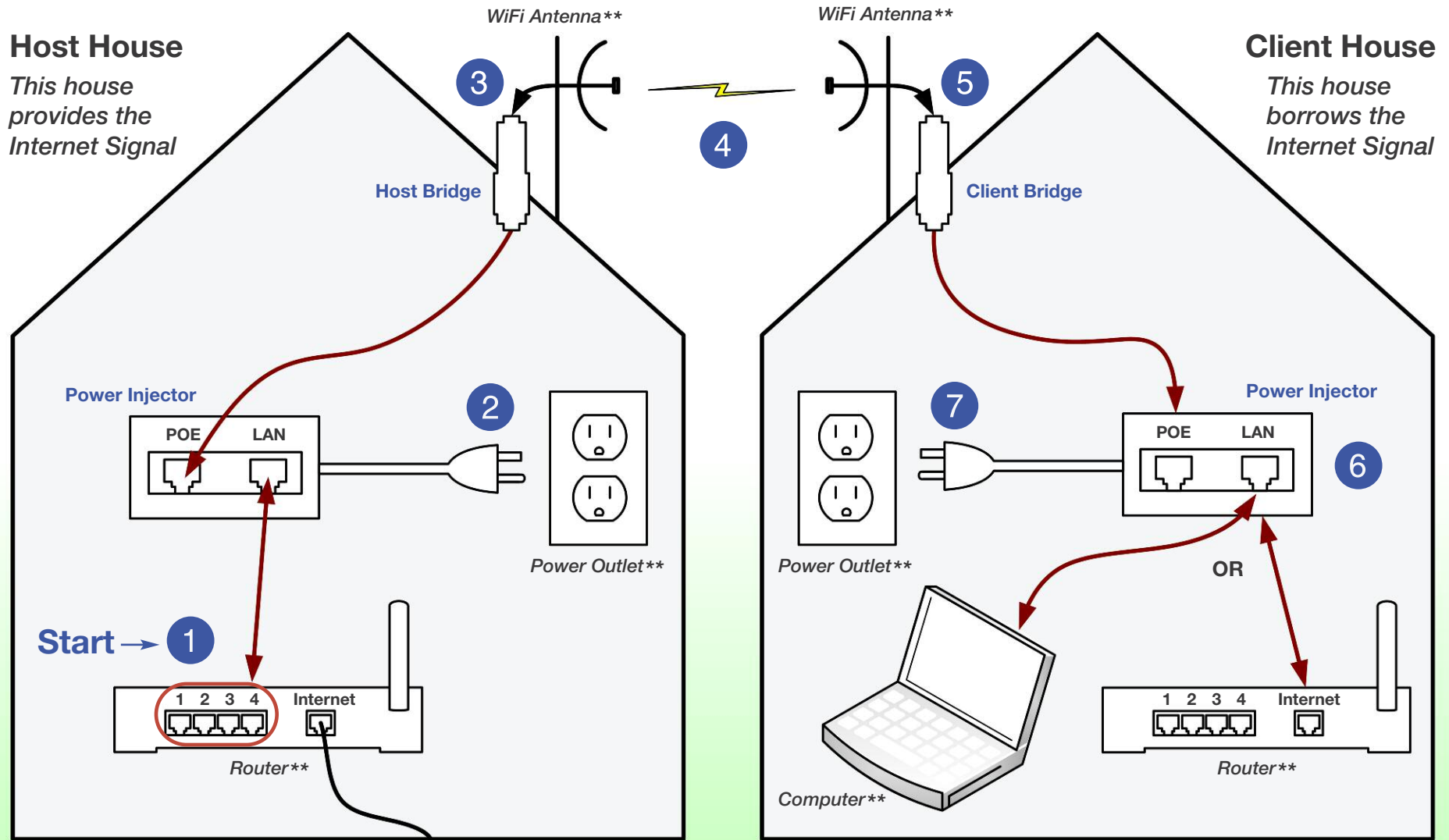

** Items not included with this kit

— = Ethernet Cable
⚡ = WiFi Connection

See other side for list of items included in this kit.

Point-to-Point Internet WiFi Kit

List of Contents

Items for Host:

- 1 Host Bridge
- 1 50-foot Ethernet Cable
- 1 5-foot Ethernet Cable
- 1 Power Injector
- 1 Pack of Coax Tape
- 1 Silicone Packet

Items for Client:

- 1 Client Bridge
- 1 50-foot Ethernet Cable
- 1 5-foot Ethernet Cable
- 1 Power Injector
- 1 Pack of Coax Tape
- 1 Silicone Packet

The equipment in this kit has been pre-configured by C. Crane to work right out of the box. Please follow the **Connection Diagram** on the reverse side and the **Point-to-Point Internet WiFi Kit Setup Guide** for proper installation.